

### Features

- RF: 6-20 GHz; IF: 1-10 GHz
- Built-in LO with 6-20 GHz control range
- Highly precise OCXO reference clock
- Conversion loss: 10 dB (typical)
- Bi-directional frequency conversion

### Applications

- Ku-band LEO Satellite
- WiFi-6e/7
- UWB Radar
- Defence Radar
- Frequency extension for general sub-6 GHz equipment



Figure 1. UD Module

### Function Block Diagram

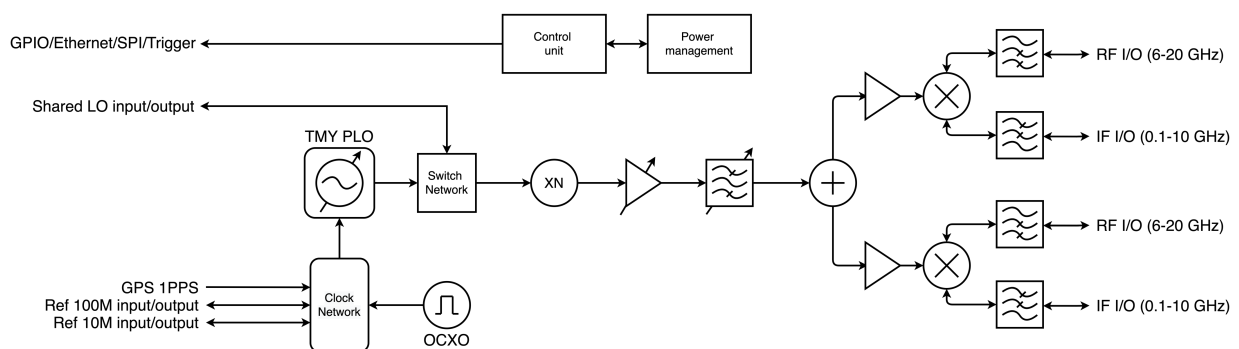

Figure 2. UD Module Block Diagram

### RF Specifications

Parameter	Conditions	Unit	Min.	Typ.	Max.
RF Frequency	---	GHz	6	---	20
IF Frequency	---	GHz	1	---	10
LO Frequency	---	GHz	6	---	20
LO Frequency Resolution	---	MHz	---	1	---
Conversion Loss	Full band	dB	8	10	13
IF to RF Isolation	---	dB	30	---	---
RF to IF Isolation	---	dB	30	---	---
Lo Leakage	Full band @ RF port	dBm	---	---	-25
Lo Leakage	Full band @ IF port	dBm	---	---	-25
RF Output P1dB	@12 GHz	dBm	0	---	---
RF Input P1dB	@12 GHz	dBm	10	---	---

Rx DSB Noise Figure	---	dB	---	13	---
RF Return Loss	Full band	dB	10	---	---
IF Return Loss	Full band	dB	10	---	---
Warm Up Time	---	minutes	---	10*	---

\* Suggested warm up time

## Clock Output Characteristics

Parameter	Conditions	Unit	Min.	Typ.	Max.
100 MHz Output Power	---	dBm	5	---	---
100 MHz Phase Noise	@10 Hz carrier offset	dBc/Hz	---		---
	@100 Hz carrier offset	dBc/Hz	---		---
	@1 kHz carrier offset	dBc/Hz	---		---
	@10 kHz carrier offset	dBc/Hz	---		---
	@100 kHz carrier offset	dBc/Hz	---		---
	@1 MHz carrier offset	dBc/Hz	---		---
10 MHz Output Power	---	dBm	8	---	---
10 MHz Phase Noise	@10 Hz carrier offset	dBc/Hz	---		---
	@100 Hz carrier offset	dBc/Hz	---		---
	@1 kHz carrier offset	dBc/Hz	---		---
	@10 kHz carrier offset	dBc/Hz	---		---
	@100 kHz carrier offset	dBc/Hz	---		---
	@1 MHz carrier offset	dBc/Hz	---		---
RMS jitter	@28 GHz	fs	20		

## Ref. Clock Input Requirement

Parameter	Conditions	Unit	Min.	Typ.	Max.
10 MHz Input Power	---	dBm	---	6	---

## AC/DC Characteristics

Parameter	Conditions	Unit	Min.	Typ.	Max.
DC Power Consumption	---	W	---	20	---
DC Input	---	V	---	15	---

## Software Specifications

Parameter	Conditions	Unit	Min.	Typ.	Max.
Switch time	---	ms	---	3	---

# Datasheet

## UD Module

UDM-MM1-0620-0110-D

PC OS	Windows 7/8/10
API Support Language	C#, C/C++, Python, LabView

### Connector Specifications

Parameter	Conditions	Location	Connector Type
RF		Front Panel	2.92-mm connectors
IF		Front Panel	2.92-mm connectors
DC Power IN		Left side	2.1-mm barrel plug
Control I/O		Left side	Micro-USB
Reference Clock I/O	10 MHz	Rear Panel	SMA connector

### Outline

Parameter	Condition	Unit	Main body	Connector included
Dimension	Length	mm	207.9	222.1
	Width	mm	177.3	177.3
	Height	mm	51	51
Weight	Unit	g	---	---

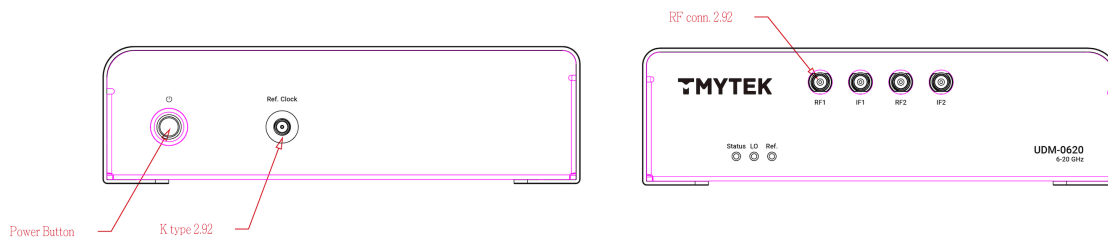

# Datasheet

## UD Module

UDM-MM1-0620-0110-D

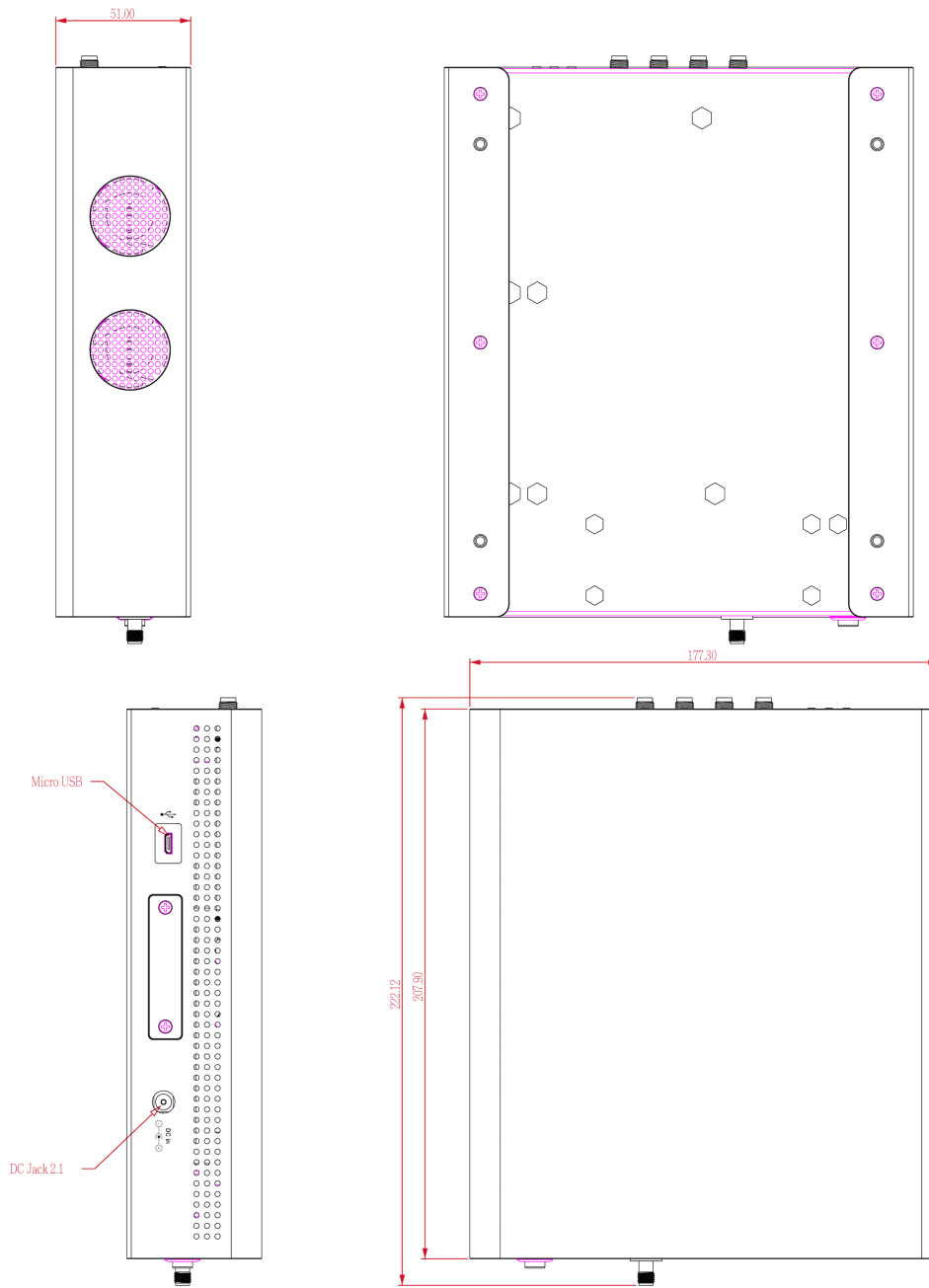

UD Module Mechanical Drawing

### Test results

#### Conversion Loss- Down conversion

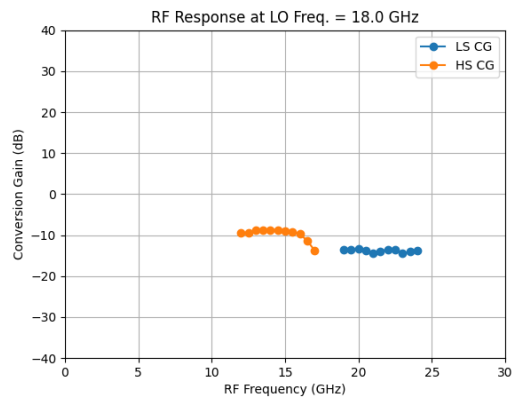
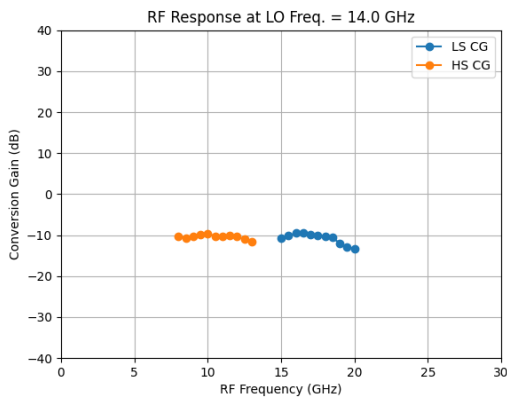
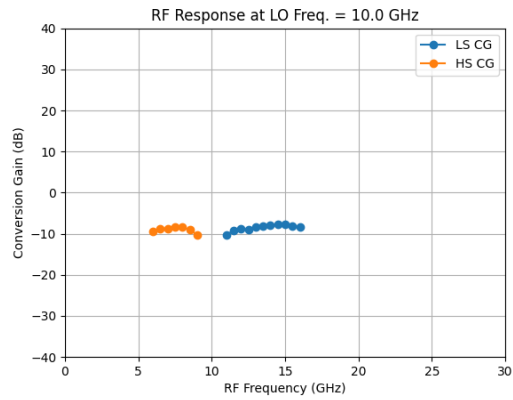
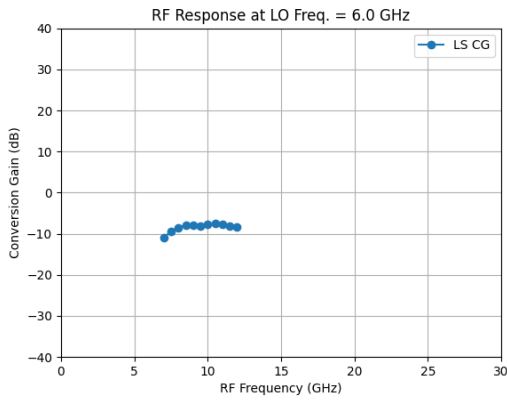

#### Conversion Loss- Up conversion

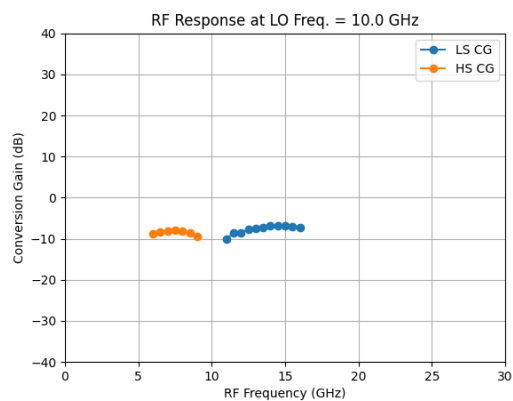
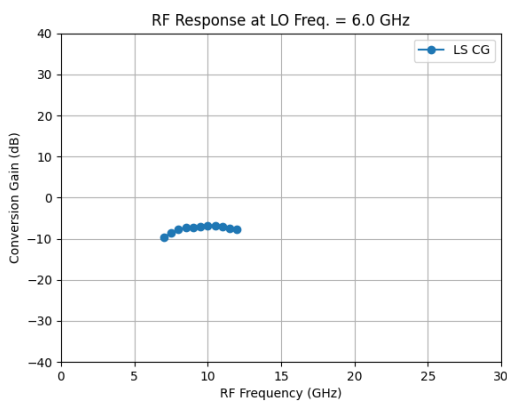

# Datasheet

## UD Module



UDM-MM1-0620-0110-D

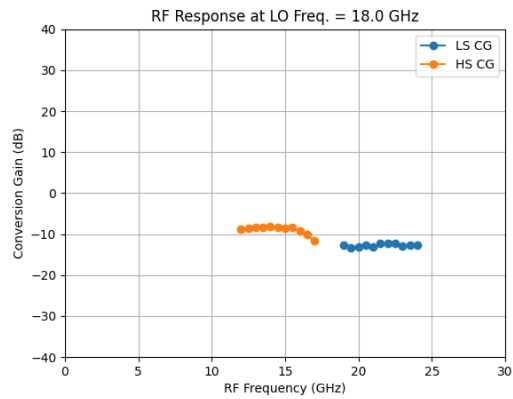
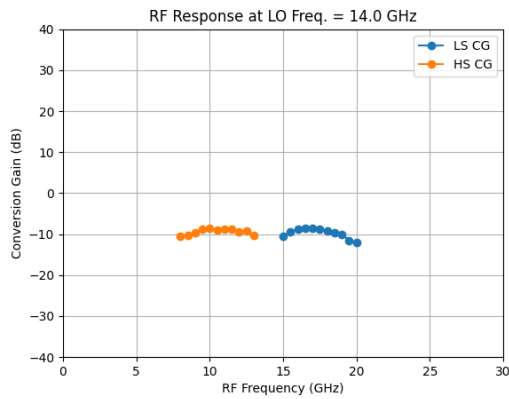

### Loopback EVM

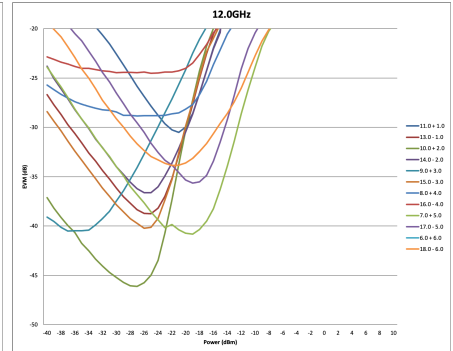
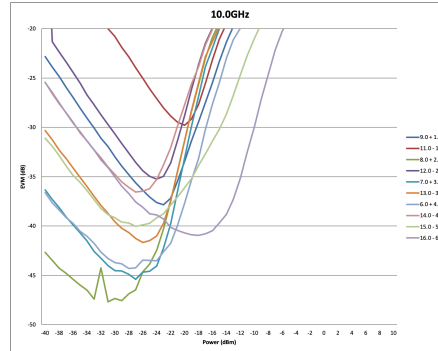
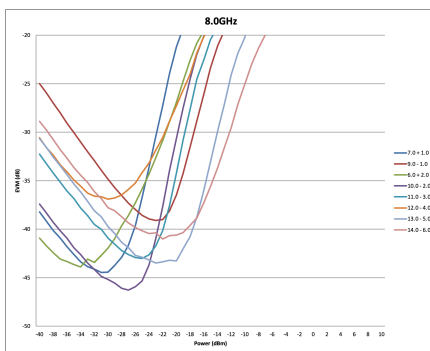

Rm. D, 3F., No. 3, Yuandong Rd., Banqiao Dist., New Taipei City 220, Taiwan

Tel: +886-8226-9168

Email: [sales@tmytek.com](mailto:sales@tmytek.com)

TMYTEK INC.

[www.tmytek.com](http://www.tmytek.com)