

### Features

- RF: 24-44 GHz; IF: 0.01- 14 GHz
- Built-in LO with 24-44 GHz control range
- Highly precise OCXO reference clock
- Conversion Loss: 13 dB (typical)
- Choices of single or dual channels
- Bi-directional circuit topology
- 10 MHz output and 100 MHz input/output synchronization
- TMYTEK-made accessories, i.e. amplifier, band-pass filter (optional)
- Key components are RoHS compliant



Figure 1. UD Box 5G (Signal is on the left, and Dual is on the right)

### Applications

- 5G NR mmWave (n257-n260)
- Satellite Ka/Q band

### Function Block Diagram

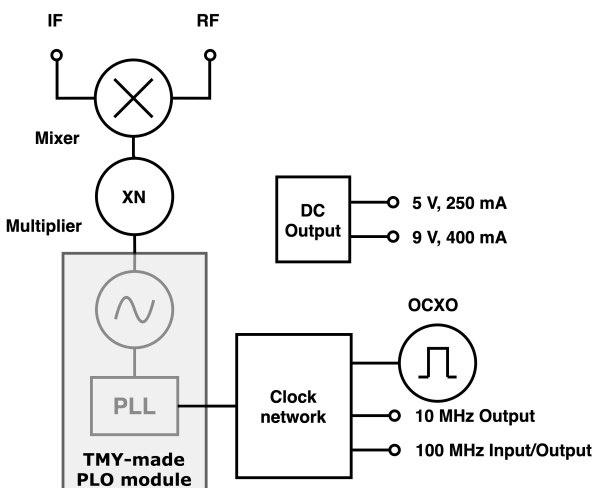

Figure 2. UD Box 5G Single Channel Block Diagram

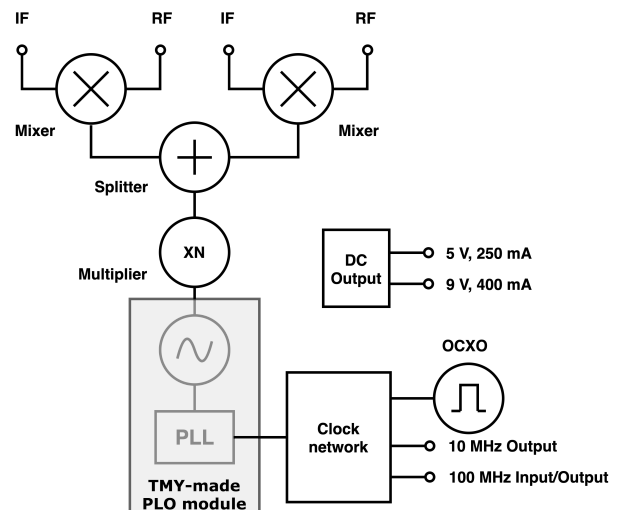

Figure 3. UD Box 5G Dual Channel Block Diagram

## RF Specifications

Parameter	Conditions	Unit	Min.	Typ.	Max.
RF Frequency	---	GHz	24	---	44
IF Frequency	---	GHz	0.01	---	14
LO Frequency	---	GHz	24	---	44
LO Frequency Resolution	---	MHz	---	0.01	---
Reference Clock Stability	-30 ~ +70 degree	ppb	-50	---	50
Conversion Loss	Full band	dB	---	13	---
IF to RF Isolation	With filter / No filter	dB	70* <sup>1</sup> / 12	---	---
RF to IF Isolation	With filter / No filter	dB	46* <sup>1</sup> / 18	---	---
Lo to RF Leakage	Full band	dBm	-22	---	---
Lo to IF Leakage	Full band	dBm	-22	---	---
Tx Output P1dB	RF = 28/39 GHz Tested at RF1 and RF2 port	dBm	0	---	---
Rx Input P1dB	RF = 28/39 GHz Tested at RF1 and RF2 port	dBm	10	---	---
RF Return Loss	Full band	dB	6	10	---
IF Return Loss	Full band	dB	8	10	---
Warm Up Time	---	minutes	---	30* <sup>2</sup>	---

\*<sup>1</sup> With optional n257 filter

\*<sup>2</sup> Suggested warm up time

## Clock Output Characteristics

Parameter	Conditions	Unit	Min.	Typ.	Max.
100 MHz Output Power	---	dBm	-3	---	---
100 MHz Phase Noise	@1 kHz carrier offset	dBc/Hz	---	-120	---
	@10 kHz carrier offset	dBc/Hz	---	-125	---
	@100 kHz carrier offset	dBc/Hz	---	-130	---
	@1 MHz carrier offset	dBc/Hz	---	-135	---
10 MHz Output Power	---	dBm	-5	---	---
10 MHz Phase Noise	@1 kHz carrier offset	dBc/Hz	---	-120	---
	@10 kHz carrier offset	dBc/Hz	---	-125	---
	@100 kHz carrier offset	dBc/Hz	---	-128	---
	@1 MHz carrier offset	dBc/Hz	---	-130	---

## DC Characteristics

Parameter	Conditions	Unit	Min.	Typ.	Max.
DC Power Consumption	---	W	---	20* <sup>1</sup>	24* <sup>2</sup>
DC Input	---	V	---	15	---
Accessories DC Power Supply	Single / Dual Channel	V	---	5/9	---
		mA	---	250/400	---

\*<sup>1</sup> Without using 5V and 9V

\*<sup>2</sup> With 5V or 9V fully loading

## AC Specifications

Parameter	Conditions	Unit	Min.	Typ.	Max.
Adapter Input Voltage	---	Vac	100	---	240
AC Input Current Consumption	---	A	---	---	0.8

## Software Specifications

Parameter	Conditions	Unit	Min.	Typ.	Max.
Switch time	---	ms	---	100	---
PC OS	Windows 7/8/10				
API Support Language	C#, C/C++, Python, LabView				
Control Interface	Ethernet				



Figure 4. Controlling UD Box 5G using TMXLAB Kit

\* The GUI above is the example of UD Box 5G Dual Channel. For a single channel, the Channel Control only appears CH1.

## Connector Specifications

Parameter	Conditions	Location	Type and Function
RF	Single Channel	Front Panel	Single 2.4 mm connector
	Dual Channel	Front Panel	Two 2.4 mm connectors
IF	Single Channel	Front Panel	Single 2.92 mm connector
	Dual Channel	Front Panel	Two 2.92 mm connectors
Power DC IN		Rear Panel	Input DC power
LAN		Rear Panel	Ethernet Port LO frequency control
ON/OFF Button		Rear Panel	Power ON/OFF switch
Reference Clock Port	10MHz	Rear Panel	BNC connector
	100 MHz	Rear Panel	SMA connector
DC Power Output Port		Rear Panel	Output 5V and 9V DC power

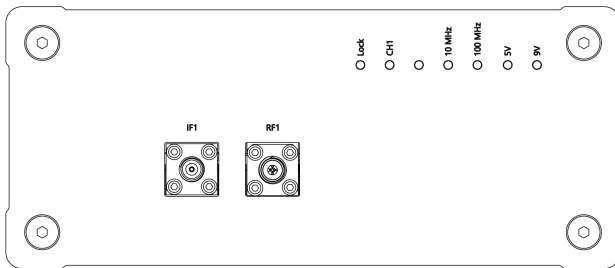

Figure 5. UD Box 5G Front Panel - Single Channel

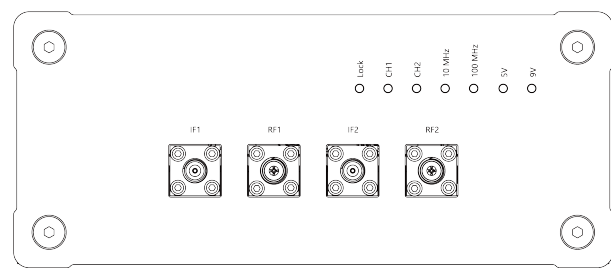

Figure 6. UD Box 5G Front Panel - Dual Channel

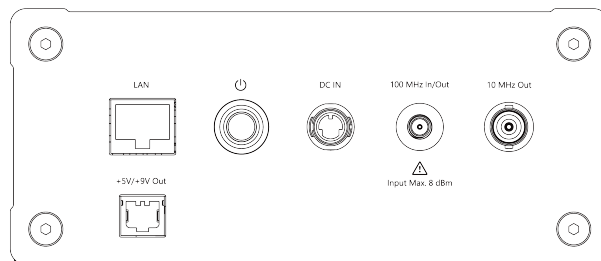

Figure 7. UD Box 5G Rear Panel – Single / Dual Channel

## Package Details

TMYTEK's connectorized packaging:

Parameter	Condition	Unit	Main body	Connector included
Dimension	Length	mm	120.6	142.8
	Width	mm	152	152
	Height	mm	65	65
Weight	unit	g	---	900
Material	Aluminum	---	---	---

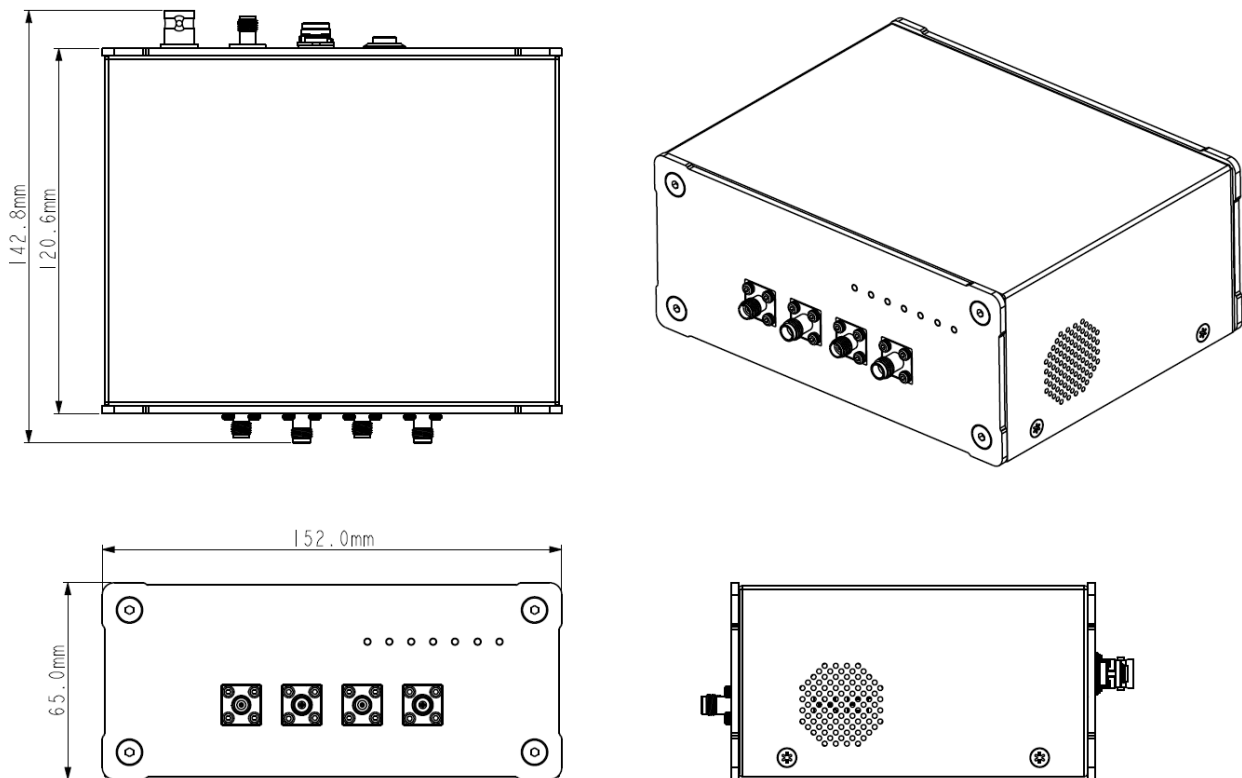

Figure 8. UD Box 5G Dual Mechanical Drawing

\* The Mechanical Drawing above is the example of UD Box 5G Dual Channel. For a single channel, it only shows one pair of IF and RF ports on the left side.

## Accessories Specifications

The following accessories are developed by TMYTEK for use with UD Box under different applications (with emphasis on the 5G application). Please consult us for detailed accessories' specifications.

Item Type	5G NR Band	Units	Operating Frequency
RF Band-Pass Filter	n257	GHz	26.5 - 29.5
	n260	GHz	37 - 40
	n261	GHz	27.5 - 28.5
Broadband Amplifier	---	GHz	20 - 40

Rm. D, 3F., No. 3, Yuandong Rd., Banqiao Dist., New Taipei City 220, Taiwan

Tel: +886-8226-9168

Email: [operation@tmytek.com](mailto:operation@tmytek.com)

TMYTEK INC.

[www.tmytek.com](http://www.tmytek.com)